

Can we get by without a mandatory energy savings target?

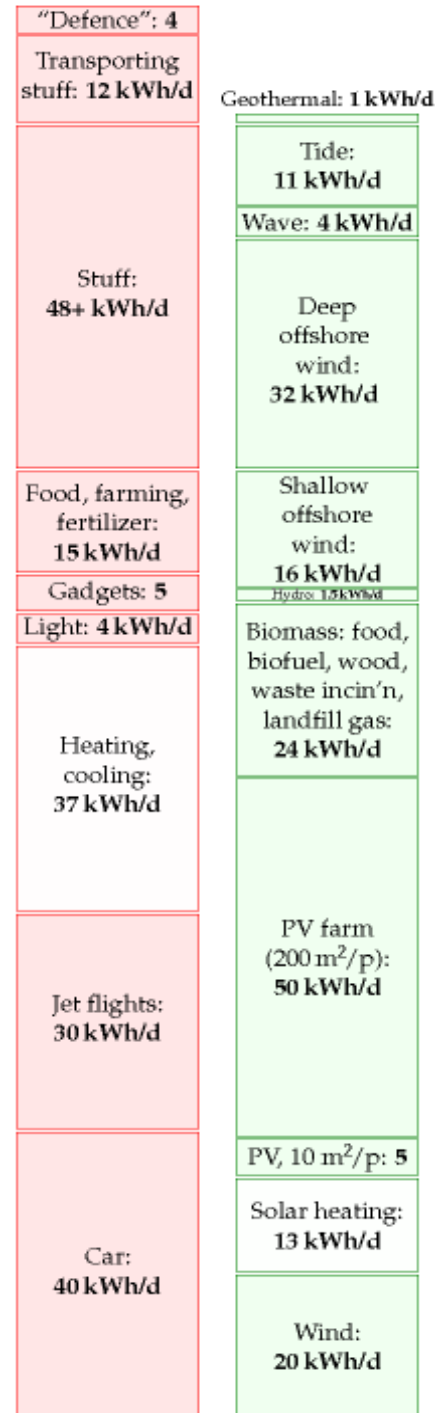

Energy ambitions meet social reality

"Defence": 4		
Transporting stuff: 12 kWh/d		
Stuff: 48+ kWh/d	Geothermal: 11 kWh/d	too immature!
	Tide: 11 kWh/d	
	Wave: 4 kWh/d	too expensive!
	Deep offshore wind: 32 kWh/d	not near my radar!
Food, farming, fertilizer: 15 kWh/d	Shallow offshore wind: 16 kWh/d	not near my birds!
Gadgets: 5	Shallow offshore wind: 16 kWh/d	not in my valley!
Light: 4 kWh/d	Biomass: food, biofuel, wood, waste incin'n, landfill gas: 24 kWh/d	not in my countryside!
Heating, cooling: 37 kWh/d		
Jet flights: 30 kWh/d	PV farm (2000 m²/p): 50 kWh/d	too expensive!
Car: 40 kWh/d	PV: 10 m²/p: 5	too expensive!
	Solar heating: 13 kWh/d	not on my street!
	Wind: 20 kWh/d	not in my back yard!

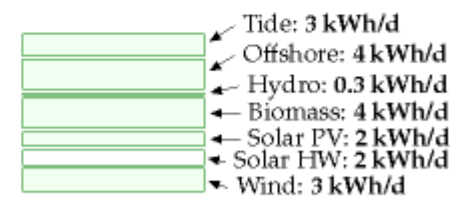
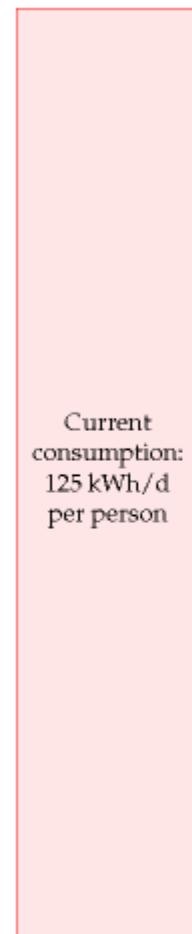

After the public consultation. I fear the maximum Britain would ever get from renewables is in the ballpark of **18 kWh/d per person**. (The left-hand consumption number, **125 kWh/d per person**, by the way, is the average British consumption, excluding imports, and ignoring solar energy acquired through food production.)



Financing: redirecting structural funds

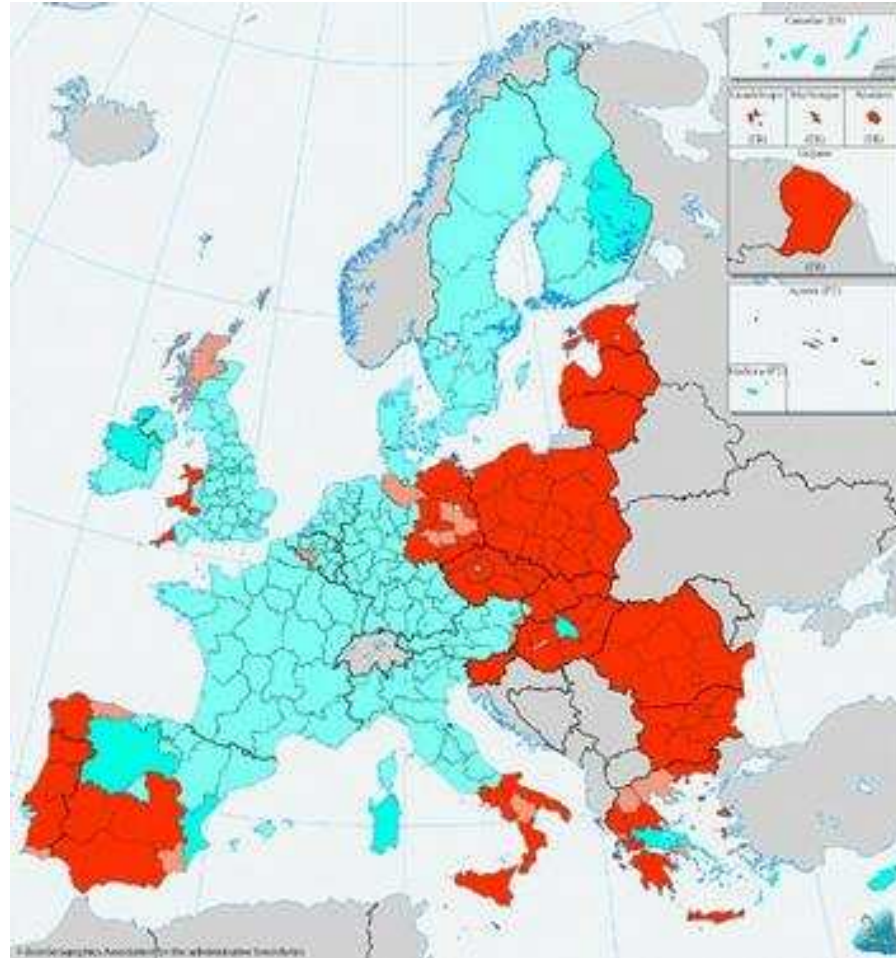

THE BIG ASK
WWW.THEBIGASK.EU
Calling for annual cuts in emissions across Europe

Friends of the Earth Europe



Financing: Carbon Taxation

Denmark

Netherlands

Norway

Slovenia

Sweden

UK



**THE
BIG
ASK**

WWW.THEBIGASK.EU



**Friends of
the Earth
Europe**

Calling for annual cuts in emissions across Europe



Setting transmission tariffs / wire charges to finance energy efficiency



**THE
BIG
ASK**

WWW.THEBIGASK.EU



**Friends of
the Earth
Europe**

Calling for annual cuts in emissions across Europe



COMMUNITY INVESTMENT



© EWEA / WINTER



**THE
BIG
ASK**

WWW.THEBIGASK.EU



**Friends of
the Earth
Europe**

Calling for annual cuts in emissions across Europe



Third party financing: ESCOs



**THE
BIG
ASK**

WWW.THEBIGASK.EU



**Friends of
the Earth
Europe**

Calling for annual cuts in emissions across Europe



A « ONE STOP SHOP » ENERGY EFFICIENCY FUND:

LINKS UP FINANCING SOURCES WITH ENERGY EFFICIENCY OPPORTUNITIES



Enter the Energy Regulators..

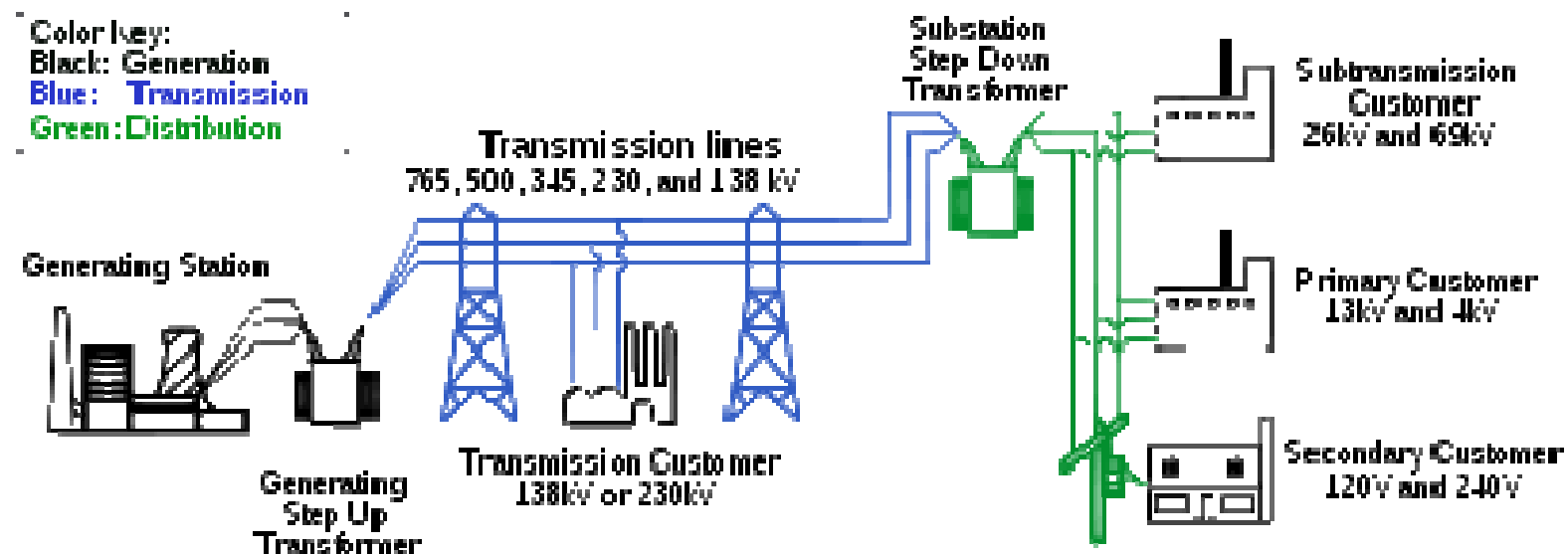

WWW.THEBIGASK.EU

Calling for annual cuts in emissions across Europe



Smart metering



WWW.THEBIGASK.EU

Calling for annual cuts in emissions across Europe



Price incentives & smart technology

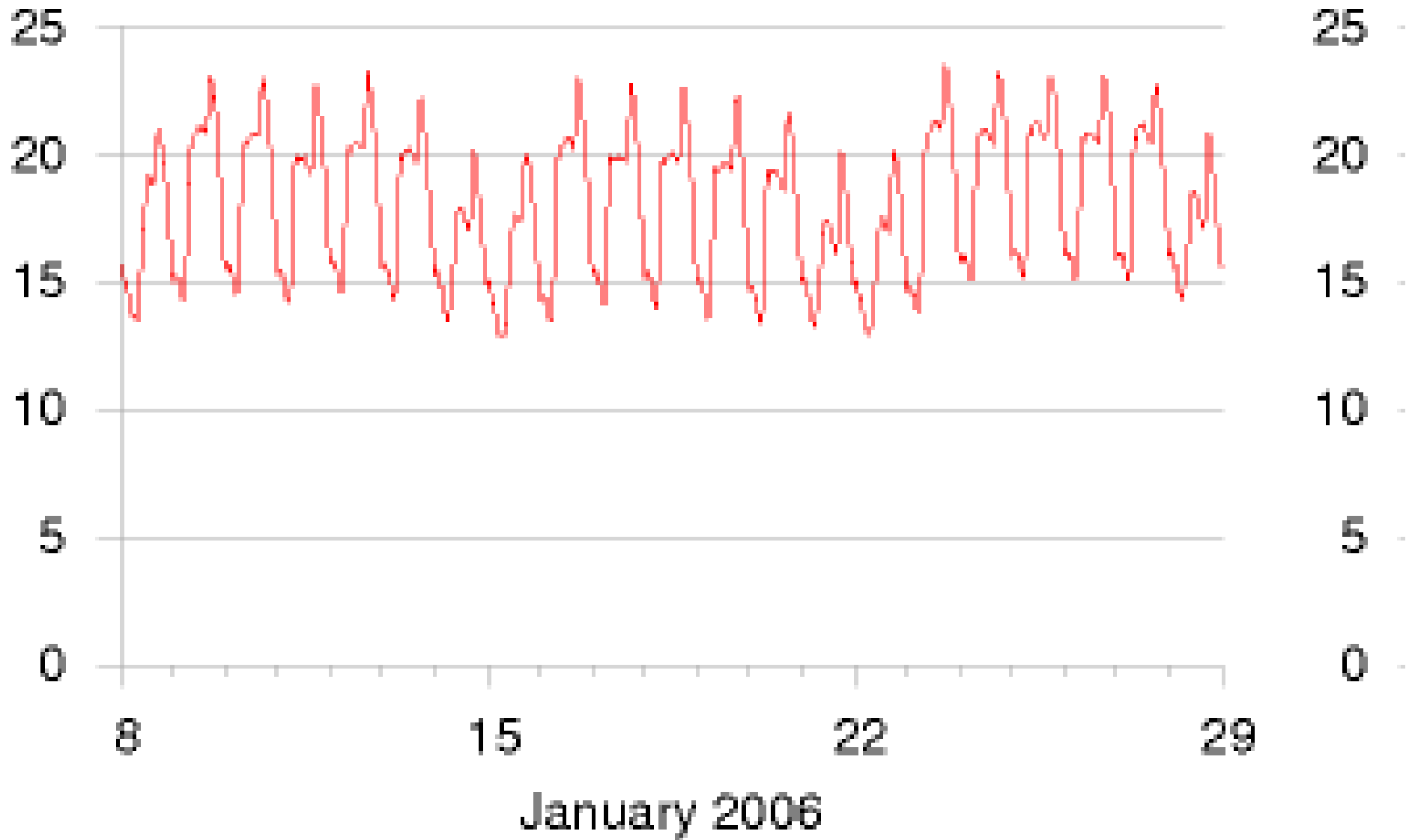



Mandatory energy savings

**Bringing the EU's energy consumption
back down to 1990 levels by 2020:**

- **Over €200 billion per year in reduced energy bills**
- **Reduced energy imports**
- **17-20% CO2 emission cuts**



Calling for annual cuts in emissions across Europe



Set a binding energy savings target for 2020

brook.riley@foeeurope.org

